

9500 - Pilot Operated



When it comes to the ultimate in high performance, we meet the absolute toughest standards in most industrial applications. Far superior to conventional relief valve designs, Mercer Valves open, close, seat and seal.

Think... **Mercer First™**

9500 Series Pilot Operated Product Overview

The 9500 Series Safety Relief Valves are state of the art in pilot operated pressure relief valves. Mercer offers both a snap and modulating pilot. Mercer pilot operated valves are constructed with the same care and precision as our other valve lines. The pilot operated valves continue using our patented "Auto Seat Technology®" in the main valve and pilot valves, making the pilot operated valves as reliable as Mercer's spring operated valves.



9500 Series Pilot Operated Features

- Designed with "Auto Seat Technology®."
- Consistent Set Pressures allowing repeatable uses without repair or resetting.
- Open, Close, Seat, and Seal™.
- Low rated and fully guided springs allow for more consistent set pressures.
- Built in accordance with the requirements of ASME Boiler and Pressure Vessel Code, Section VIII, Div. I
- Non-rising stems allowing valves to be installed in small areas.

9500 Series Pilot Operated Specifications • API Orifice

Orifice Letter	Standard Inlet Sizes	Actual Orifice Diameter (in)	Actual Orifice Area (in ²)	API Orifice Area (in ²)	Pressure Ranges (psi)	Standard Temp Range (°F)	Flow Coefficient, K _d (Gas)	Flow Coefficient, K _d (Liquid)
D	1", 1 1/2"	.439	.151	.110	15 to 3750	-15 to 400	.870	---
E	1", 1 1/2"	.533	.223	.196	15 to 3750	-15 to 400	.870	---
F	1", 1 1/2"	.687	.371	.307	15 to 3750	-15 to 400	.870	.731
G	1 1/2", 2"	.844	.559	.503	15 to 3750	-15 to 400	.870	---
H	1 1/2", 2"	1.050	.866	.785	15 to 3750	-15 to 400	.870	.731 (1 1/2" inlet only)
J	2", 3"	1.350	1.431	1.287	15 to 2000	-15 to 400	.870	.731 (2" inlet only)
K	3"	1.625	2.074	1.838	15 to 2000	-15 to 400	.870	---
L	3", 4"	2.020	3.205	2.853	15 to 2000	-15 to 400	.870	.731 (3" inlet only)
M	4"	2.280	4.083	3.600	15 to 2000	-15 to 400	.870	.731
N	4"	2.500	4.909	4.430	15 to 2000	-15 to 400	.870	---
P	4"	3.000	7.069	6.380	15 to 1480	-15 to 400	.870	.731
Q	6"	4.000	12.566	11.050	15 to 1480	-15 to 400	.870	---
R	6"	4.750	17.721	16.000	15 to 1480	-15 to 400	.870	.731
T	8"	5.750	25.967	26.000	15 to 1480	-15 to 400	.870	.731

NOTES: 1) Mercer Liquid Pilots are modulating type pilots only. Max Pressure of 1480 PSI.
2) Mercer Valve reserves the right to change product designs and specifications without notice.
3) Modulating Pilot pressure range from 15 to 1480 PSI.

9500 Series Pilot Operated Specifications • Full Bores

Orifice Letter	Standard Inlet Sizes	Actual Orifice Diameter (in)	Actual Orifice Area (in ²)	Pressure Ranges (psi)	Standard Temp Range (°F)	Flow Coefficient, K _v (Gas)
1 1/2" FB	1 1/2"	1.500	1.767	15 to 2000	-15 to 400	.820
2" FB	2"	1.939	2.953	15 to 2000	-15 to 400	.820
3" FB	3"	2.900	6.605	15 to 1480	-15 to 400	.820
4" FB	4"	3.825	11.491	15 to 1480	-15 to 400	.820
6" FB	6"	5.761	26.067	15 to 1480	-15 to 400	.820
8" FB	8"	7.625	45.664	15 to 1480	-15 to 400	.820

NOTES: 1) Mercer Valve reserves the right to change product designs and specifications without notice.
2) Modulating Pilot pressure range from 15 to 1480 PSI.

9500 Series Pilot Operated Parts and Materials

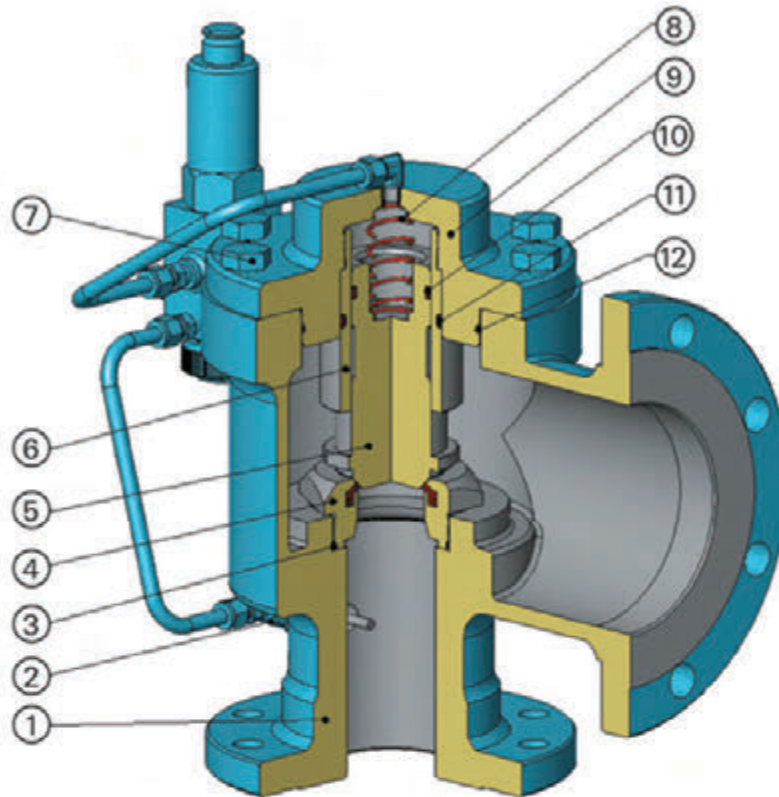

9500 SERIES MAIN VALVE

ITEM NO	PART NAME	STANDARD MATERIAL
1	MAIN VALVE BODY	CARBON STEEL
2	PRESSURE PROBE SUBASSEMBLY	CARBON STEEL WITH STNLS STEEL TRIM
3	NOZZLE O-RING	VITON
4	NOZZLE SUBASSEMBLY	STAINLESS STEEL WITH SOFT SEAT
5	PISTON SUBASSEMBLY	STAINLESS STEEL
6	PISTON SLEEVE	STAINLESS STEEL WITH NEDOX® COATING
7	BONNET BOLTS	CARBON STEEL
8	RETURN SPRING	STAINLESS STEEL
9	MAIN VALVE BONNET	CARBON STEEL
10	PISTON O-RING	VITON
11	PISTON SLEEVE O-RING	VITON
12	BONNET O-RING	VITON

NOTES: 1) All Tubing and Fittings are 316 STNLS STL
 2) Reference pilot drawings for pilot information
 3) Mercer Valve reserves the right to change product designs and specifications without notice.

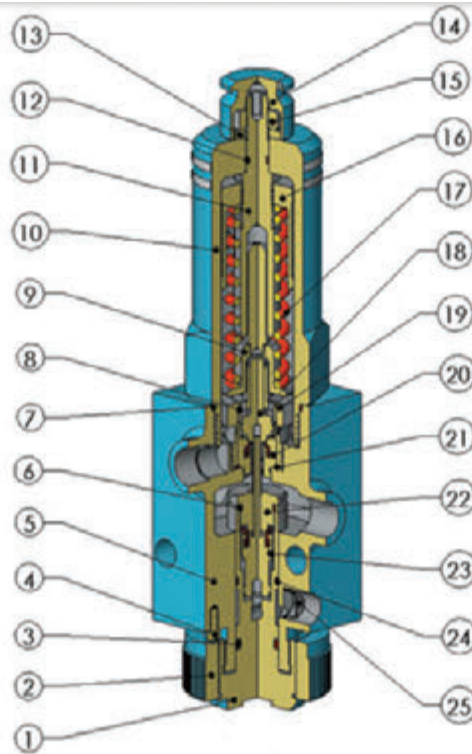

9500 SERIES SNAP PILOT

ITEM NO	PART NAME	STANDARD MATERIAL
1	CAGE SUBASSEMBLY	STAINLESS STEEL
2	BLOWDOWN ADJUSTMENT SLEEVE	CARBON STEEL
3	CAGE LOWER O-RING	VITON
4	BLOWDOWN STOP	CARBON STEEL
5	SNAP PILOT BODY	CARBON STEEL
6	STATIONARY SEAT O-RING	VITON
7	BONNET O-RING	VITON
8	DISK GUIDE	STAINLESS STEEL
9	SPRING GUIDE SUBASSEMBLY	STAINLESS STEEL
10	SUBASSEMBLY BONNET	CARBON STEEL
11	ADJUSTMENT SCREW	STAINLESS STEEL
12	ADJUSTMENT SCREW O-RING	VITON
13	WASHER	CARBON STEEL
14	CLOSED CAP	ALUMINUM ALLOY
15	LOCKNUT	CARBON STEEL
16	ADJUSTMENT BUSHING	STAINLESS STEEL
17	SET SPRING	STAINLESS STEEL
18	UPPER DISK	STAINLESS STEEL
19	RETENTION NUT	STAINLESS STEEL
20	UPPER NOZZLE SUBASSEMBLY	STAINLESS STEEL WITH SOFT SEAT
21	UPPER NOZZLE O-RING	VITON
22	STATIONARY SEAT	STAINLESS STEEL
23	SHUTTLE SUBASSEMBLY	STAINLESS STEEL WITH SOFT SEAT
24	CAGE UPPER O-RING	VITON
25	PILOT BODY FILTER	STAINLESS STEEL

NOTE: Mercer Valve reserves the right to change product designs and specifications without notice.

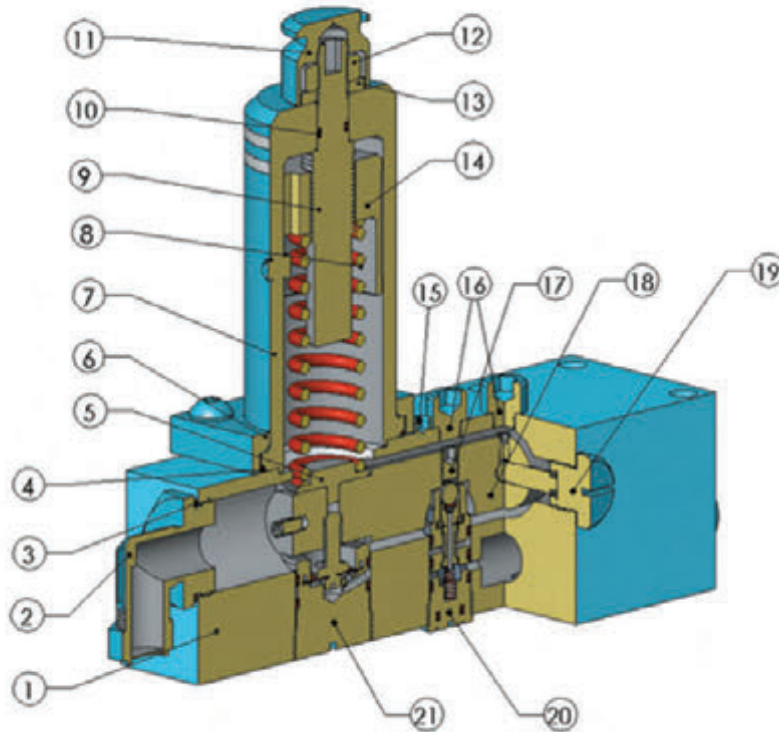

9500 SERIES MODULATING PILOT

ITEM NO	PART NAME	STANDARD MATERIAL
1	PILOT BODY	CARBON STEEL
2	PILOT VENT	BRASS WITH STAINLESS STEEL FILTER
3	VENT O-RING	VITON
4	BONNET O-RING	VITON
5	SPRING GUIDE	STAINLESS STEEL
6	BONNET RETAINING RING	CARBON STEEL
7	BONNET SUBASSEMBLY	CARBON STEEL
8	SET SPRING	STAINLESS STEEL
9	ADJUSTMENT SCREW	STAINLESS STEEL
10	ADJUSTMENT SCREW O-RING	VITON
11	CLOSED CAP	ALUMINUM ALLOY
12	LOCKNUT	CARBON STEEL
13	WASHER	CARBON STEEL
14	ADJUSTMENT BUSHING	STAINLESS STEEL
15	BEAM LIMIT SET SCREW	STAINLESS STEEL
16	CAP HEAD SEAL SCREWS	CARBON STEEL
17	CONTROL MODULE SET SCREW	STAINLESS STEEL
18	BEAM	ALUMINUM ALLOY
19	BEARING SCREWS	STAINLESS STEEL
20	CONTROL MODULE	STAINLESS STEEL WITH SOFT SEALS
21	INPUT MODULE	STAINLESS STEEL WITH SOFT SEALS

NOTE: Mercer Valve reserves the right to change product designs and specifications without notice.

9500 Series Pilot Operated Dimensions and Weights

Inlet and Outlet Code	Inlet and Outlet Size	Orifice Available	Dimensions "A" x "B" x "C" (in ±1/16)	Approx. Weight (lbs)
27	1" 150lb x 2" 150lb	D, E, F	4-1/8 x 4-1/2 x 12-1/8	40
28	1" 300lb x 2" 150lb	D, E, F	4-3/8 x 4-1/2 x 12-3/8	40
29	1" 600lb x 2" 150lb	D, E, F	4-3/8 x 4-1/2 x 12-3/8	40
31	1" 900lb x 2" 300lb	D, E, F	4-15/16 x 4-3/4 x 12-15/16	50
32	1" 1500lb x 2" 300lb	D, E, F	4-15/16 x 4-3/4 x 12-15/16	50
32.2	1" 2500lb x 2" 300lb	D, E, F	4-15/16 x 4-3/4 x 12-15/16	55
33	1 1/2" 150lb x 2" 150lb	D, E, F, 1 1/2" FB	4-7/8 x 4-3/4 x 12-7/8	45
34	1 1/2" 300lb x 2" 150lb	D, E, F, 1 1/2" FB	4-7/8 x 4-3/4 x 12-7/8	45
35	1 1/2" 600lb x 2" 150lb	D, E, F, 1 1/2" FB	4-7/8 x 4-3/4 x 12-7/8	45
36	1 1/2" 900lb x 2" 300lb	D, E, F, 1 1/2" FB	5-7/8 x 5-1/2 x 13-7/8	55
36.1	1 1/2" 1500lb x 2" 300lb	D, E, F, 1 1/2" FB	5-7/8 x 5-1/2 x 13-7/8	55
36.2	1 1/2" 2500lb x 2" 300lb	D, E, F, 1 1/2" FB	5-7/8 x 5-1/2 x 13-7/8	60
55	1 1/2" 150lb x 3" 150lb	G, H, 1 1/2" FB	5-1/8 x 4-7/8 x 13-3/16	50
56	1 1/2" 300lb x 3" 150lb	G, H, 1 1/2" FB	5-1/8 x 4-7/8 x 13-3/16	50
74	1 1/2" 600lb x 3" 150lb	G, H, 1 1/2" FB	5-1/8 x 4-7/8 x 13-3/16	55
75	1 1/2" 900lb x 3" 300lb	G, H, 1 1/2" FB	6-3/8 x 6-3/4 x 14-7/16	60
75.1	1 1/2" 1500lb x 3" 300lb	G, H, 1 1/2" FB	6-3/8 x 6-3/4 x 14-7/16	60
75.2	1 1/2" 2500lb x 3" 300lb	G, H, 1 1/2" FB	6-3/8 x 6-3/4 x 14-7/16	65
51	2" 150lb x 3" 150lb	G, H, J, 2" FB	5-3/8 x 4-7/8 x 13-7/16	50
52	2" 300lb x 3" 150lb	G, H, J, 2" FB	5-3/8 x 4-7/8 x 13-7/16	50
53	2" 600lb x 3" 150lb	G, H, J, 2" FB	5-3/8 x 4-7/8 x 13-7/16	55
54	2" 900lb x 3" 300lb	G, H, J, 2" FB	6-9/16 x 6-3/4 x 14-5/8	60
54.1	2" 1500lb x 3" 300lb	G, H, J, 2" FB	6-9/16 x 6-3/4 x 14-5/8	60
54.2	2" 2500lb x 3" 300lb	G, H, J, 2" FB	7 x 6-3/4 x 15-1/16	65
54.3	2" 1500lb x 3" 600lb	J, 2" FB	6-9/16 x 6-3/4 x 14-5/8	65
54.4	2" 2500lb x 3" 600lb	J, 2" FB	7 x 6-3/4 x 15-1/16	70
62	3" 150lb x 4" 150lb	J, K, L, 3" FB	6-1/8 x 6-3/8 x 15-1/8	90
64	3" 300lb x 4" 150lb	J, K, L, 3" FB	6-1/8 x 6-3/8 x 15-1/8	90
65	3" 600lb x 4" 150lb	J, K, L, 3" FB	6-3/8 x 6-3/8 x 15-3/8	95
65.1	3" 600lb x 4" 300lb	L, 3" FB	7-1/2 x 7-1/8 x 16-1/2	100
66.1	3" 900lb x 4" 300lb	J, K, L, 3" FB	7-1/2 x 7-1/8 x 16-1/2	105
66.2	3" 1500lb x 4" 300lb	J, K, L, 3" FB	7-1/2 x 7-1/8 x 16-1/2	105
66.3	3" 1500lb x 4" 600lb	L, 3" FB	7-1/8 x 7-5/8 x 16-1/8	110

NOTE: Mercer Valve reserves the right to change product designs and specifications without notice.

Inlet / Outlet Code	Inlet and Outlet Size	Orifice Available	Dimensions "A" x "B" x "C" (in ±1/16)	Approx. Weight (lbs)
70	4" 150lb x 6" 150lb	L, M, N, P, 4" FB	7-3/4 x 8-1/4 x 17-3/8	200
71	4" 300lb x 6" 150lb	L, M, N, P, 4" FB	7-3/4 x 8-1/4 x 17-3/8	200
72	4" 600lb x 6" 150lb	L, M, N, P, 4" FB	7-3/4 x 8-1/4 x 17-3/8	210
72.1	4" 600lb x 6" 300lb	P, 4" FB	9-13/16 x 9-3/16 x 19-1/2	210
73.1	4" 900lb x 6" 300lb	L, M, N, P, 4" FB	9-13/16 x 9-3/16 x 19-1/2	220
73.2	4" 1500lb x 6" 300lb	L, M, N, P, 4" FB	9-13/16 x 9-3/16 x 19-1/2	220
73.3	4" 1500lb x 6" 600lb	P, 4" FB	9-13/16 x 10-3/8 x 19-1/2	230
76	6" 150lb x 8" 150lb	Q, R	9-7/16 x 9-1/2 x 22-5/8	425
77	6" 300lb x 8" 150lb	Q, R	9-7/16 x 9-1/2 x 22-5/8	430
78	6" 600lb x 8" 150lb	Q, R	9-11/16 x 9-1/2 x 22-7/8	440
76x	6" 150lb x 8" 150lb x 8" 150lb	Q, R, 6" FB	9-7/16 x 9-1/2 x 22-5/8	470
77x	6" 300lb x 8" 150lb x 8" 150lb	Q, R, 6" FB	9-7/16 x 9-1/2 x 22-5/8	475
78x	6" 600lb x 8" 150lb x 8" 150lb	Q, R, 6" FB	9-11/16 x 9-1/2 x 22-7/8	485
81	8" 150lb x 10" 150lb	T	10-7/8 x 11 x 25-1/2	520
82	8" 300lb x 10" 150lb	T	10-7/8 x 11 x 25-1/2	530
83	8" 600lb x 10" 150lb	T	11-11/16 x 11 x 26-5/16	540
81x	8" 150lb x 10" 150lb x 10" 150lb	T, 8" FB	10-7/8 x 11 x 25-1/2	575
82x	8" 300lb x 10" 150lb x 10" 150lb	T, 8" FB	10-7/8 x 11 x 25-1/2	585
83x	8" 600lb x 10" 150lb x 10" 150lb	T, 8" FB	11-11/16 x 11 x 26-5/16	595

NOTE: Mercer Valve reserves the right to change product designs and specifications without notice.

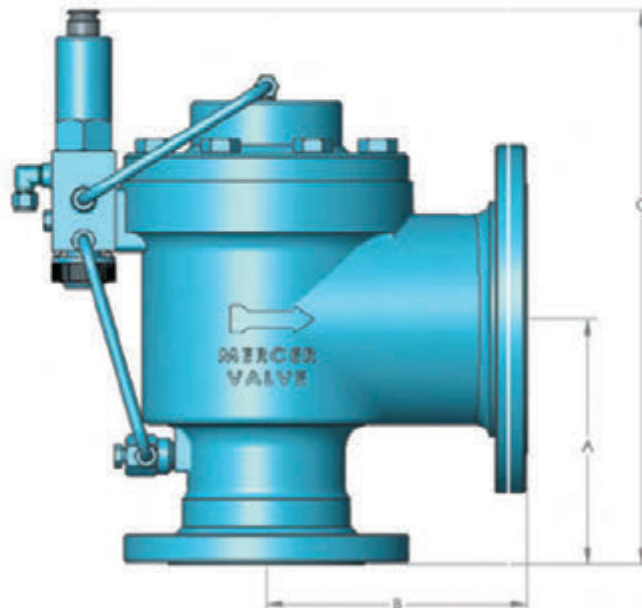

Snap Pilot Operation

The system pressure is sensed in the snap pilot through a pressure pickup located at the inlet of the main valve. With the lower shuttle seat open and the upper seat sealed, the pressure travels around the shuttle, through the pilot, and into the main valve dome. Because the dome area is larger than the main valve orifice area, the pressure acting downward on the piston will assure that the valve remains tightly sealed.

The upper seat remains closed while the system is below set pressure. There is a rod that connects the upper seat with the lower shuttle seat. This rod is the device that keeps the lower seat open when the upper seat is closed. When the system reaches set pressure, the upper seat "snaps" open, which in turn allows the lower shuttle seat to close. This permits the air in the main valve dome to exit back through the pilot and vent to atmosphere. Instantaneously, the main valve opens and relieves the system. The system pressure will relieve until the pre-set blowdown is achieved. At that time, the pilot upper seat closes, the lower shuttle opens, and the main valve dome is re-filled causing the main valve to close.

The Mercer Valve 9500 Series Snap Pilot has an adjustable blowdown. The blowdown adjustment nut on the snap pilot alters the set spring deflection when the valve has popped. The greater the deflection the shorter the blowdown.

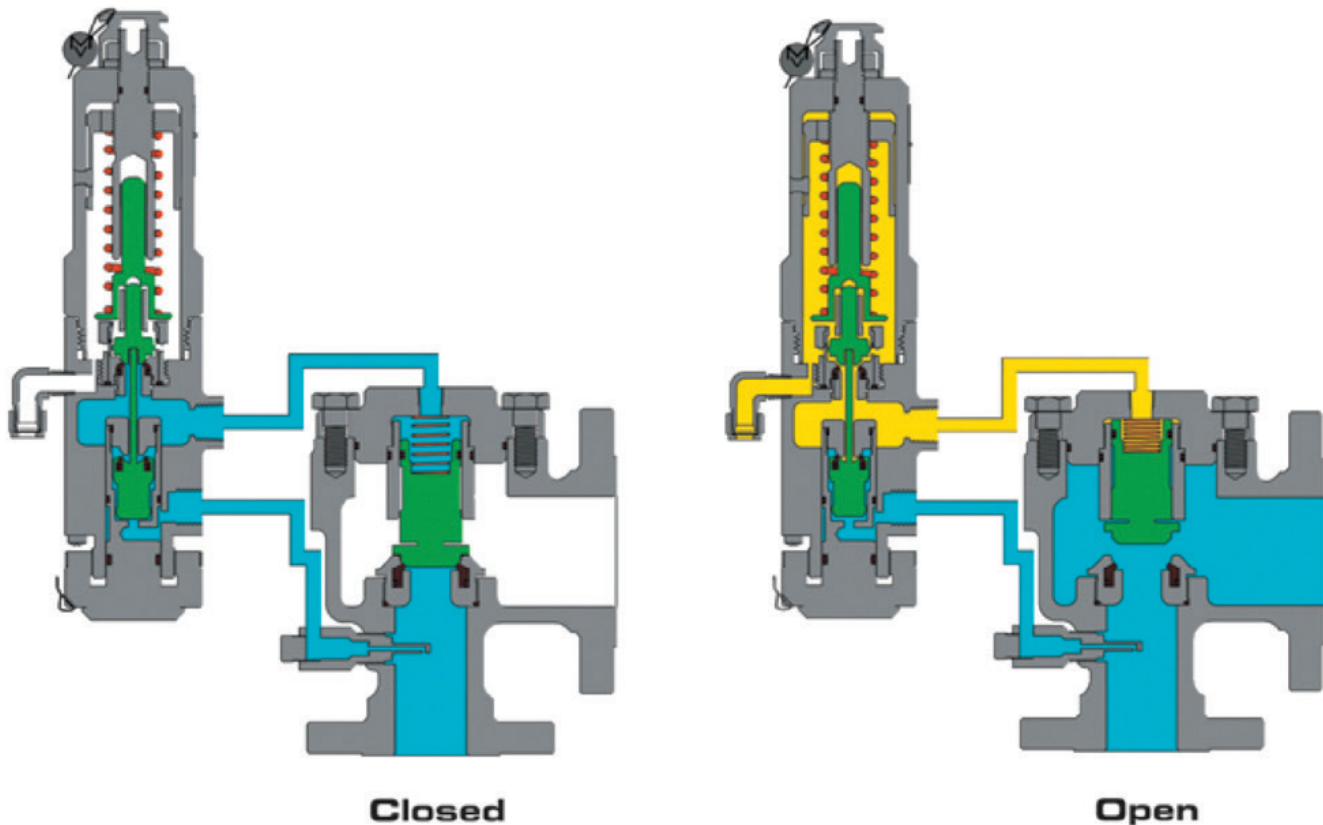

Modulating Pilot Operation

Mercer Valve Company's Modulating Pilot is designed to gradually open the main valve in response to the system overpressure. This is very different from the snap action pilot where the main valve is abruptly "snapped" open, then closed. Modulating pilot valves produce far less shock on the system, and there is considerably less wear and tear on the main valve components.

Mercer's Modulating Pilot is based on proven control design principals, where a comparison is constantly made between the vessel pressure and set pressure. When the vessel pressure exceeds the set pressure, the resulting error signal activates a unique control valve within the modulating pilot. The control valve reduces the main valve dome pressure in proportion to the amount of the vessel overpressure, thus opening the main valve and limiting the vessel pressure. As the vessel pressure is reduced below the set pressure, the main valve dome pressure gradually rises and the main valve is closed.

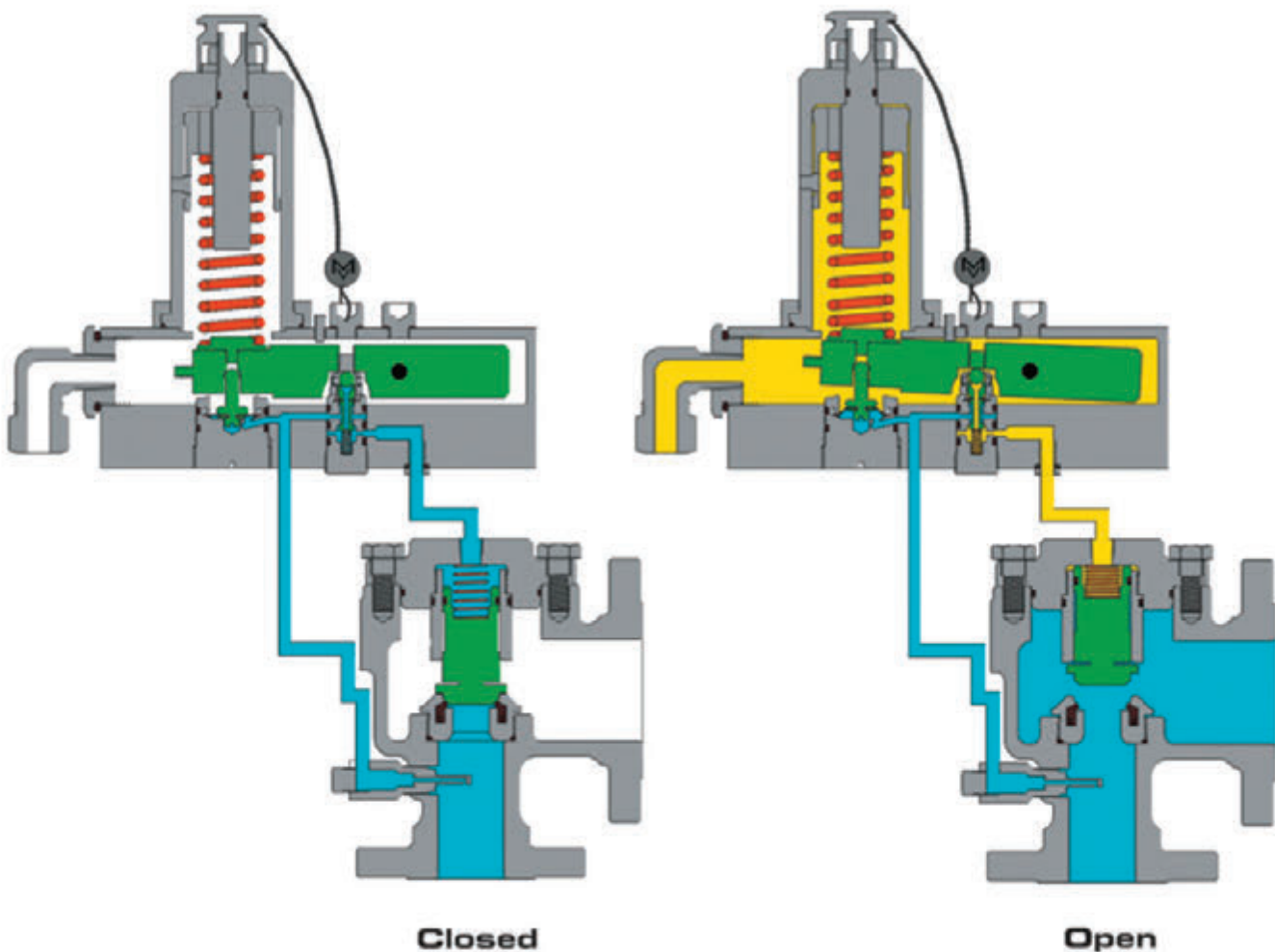

CAPACITY IN GPM OF WATER AT 60°F AND STD ATMOSPHERIC CONDITIONS

Set Press (psi)	F 0.371	H 0.866	J 1.431	L 3.205	M 4.083	P 7.069	R 17.721	T 25.967
15	44	102	169	378	481	833	2088	3060
20	49	115	191	427	544	942	2361	3459
25	55	127	210	471	600	1039	2605	3817
30	59	138	228	511	652	1128	2828	4143
50	76	178	295	660	841	1456	3651	5349
75	94	218	361	809	1030	1783	4471	6551
100	108	252	417	934	1189	2059	5163	7565
125	121	282	466	1044	1330	2302	5772	8458
150	132	309	511	1144	1457	2522	6323	9265
200	153	357	590	1320	1682	2912	7301	10698
300	187	437	722	1617	2060	3567	8942	13103
400	216	505	834	1867	2379	4119	10325	15130
500	242	564	932	2088	2660	4605	11544	16916
600	265	618	1021	2287	2914	5044	12646	18530
700	286	667	1103	2470	3147	5449	13659	20015
800	306	714	1179	2641	3364	5825	14602	21397
900	324	757	1251	2801	3568	6178	15488	22695
1000	342	798	1318	2953	3762	6512	16326	23922
1200	374	874	1444	3234	4121	7134	17884	26206

Full Bores

CAPACITY IN SCFM OF AIR AT 60°F AND STD ATMOSPHERIC CONDITIONS

Set Press (psi)	1 1/2" FB 1.767	2" FB 2.953	3" FB 6.605	4" FB 11.491	6" FB 26.067	8" FB 45.664
15	869	1451	3247	5648	12813	22445
20	1001	1673	3743	6512	14772	25877
25	1134	1895	4239	7375	16731	29309
30	1267	2117	4736	8239	18690	32741
50	1851	3094	6920	12039	27310	47842
75	2582	4314	9650	16789	38085	66718
100	3312	5535	12381	21539	48860	85593
125	4043	6756	15111	26289	59636	104469
150	4773	7976	17841	31039	70411	123345
200	6234	10418	23302	40539	91961	161097
300	9155	15300	34223	59539	135062	236600
400	12077	20183	45144	78539	178162	312104
500	14999	25066	56065	97538	221263	387607
600	17920	29948	66986	116538	264364	463111
700	20842	34831	77907	135538	307464	538614
800	23764	39714	88828	154538	350565	614117
900	26685	44596	99749	173538	393666	689621
1000	29607	49479	110670	192538	436766	765124
1200	35450	59244	132512	230537	522968	916131
1480	43631	72916	163091	283737	643649	1127541
1800	52980	88540				
2000	58824	98306				

CAPACITY IN SCFM OF 0.6 SG NATURAL GAS AT 60°F AND STD ATMOSPHERIC CONDITIONS

Set Press (psi)	1 1/2" FB 1.767	2" FB 2.953	3" FB 6.605	4" FB 11.491	6" FB 26.067	8" FB 45.664
15	1083	1811	4050	7046	15984	28000
20	1249	2088	4669	8123	18427	32281
25	1415	2364	5289	9201	20871	36562
30	1580	2641	5908	10278	23315	40844
50	2309	3859	8633	15018	34069	59682
75	3221	5382	12039	20944	47511	83229
100	4132	6905	15444	26869	60952	106776
125	5043	8428	18850	32795	74394	130323
150	5954	9951	22256	38720	87836	153871
200	7776	12996	29068	50571	114720	200965
300	11421	19087	42692	74273	168487	295154
400	15066	25178	56316	97975	222254	389343
500	18711	31269	69940	121677	276021	483532
600	22355	37360	83564	145379	329788	577721
700	26000	43451	97187	169081	383556	671910
800	29645	49542	110811	192783	437323	766099
900	33289	55633	124435	216485	491090	860288
1000	36934	61724	138059	240187	544857	954477
1200	44224	73906	165307	287591		
1480	54429	90961	203453	353956		
1800	66092	110452				
2000	73381	122634				

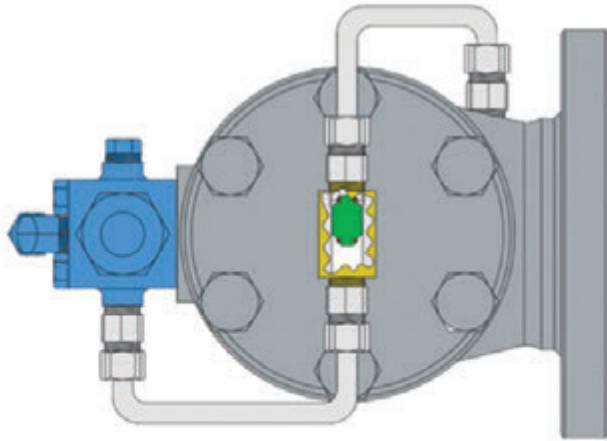

BACKFLOW PREVENTER

In certain applications, the back pressure may exceed the inlet pressure, causing the main valve to reverse leak or possibly open and flow backward. The backflow preventer is designed to stop the reverse flow in these conditions.

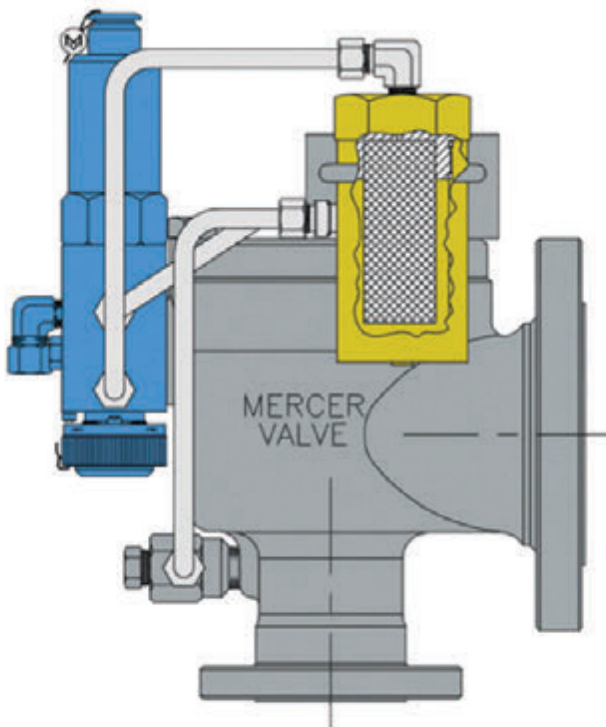

AUXILIARY SUPPLY FILTER

The auxiliary supply filter may be desired in environments where dirt, rust, or other materials could be mixed with the working media. This filter is in addition to the standard filter supplied in the inlet. Mercer Valve recommends the auxiliary supply filter for all liquid applications.

NOTE: Mercer Valve reserves the right to change product designs and specifications without notice.

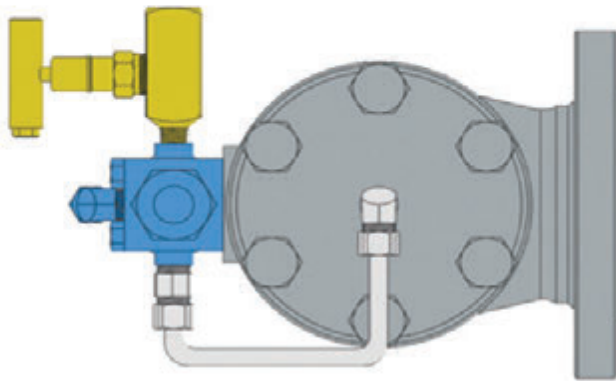

FIELD TEST CONNECTION

A portable or alternate pressure source can be applied to the pilot to verify the set pressure while keeping the valve in service. The test media that is introduced into the pilot valve is routed into the main valve dome until the set pressure is reached. In the standard field test connection an in-line check valve is supplied to assure that the test media does not affect the operating media. The offshore field test connection allows the media to pressurize the main valve inlet. With the offshore field test connection, a ball valve is required underneath the main valve. The offshore field test connection is only available on the snap pilot.

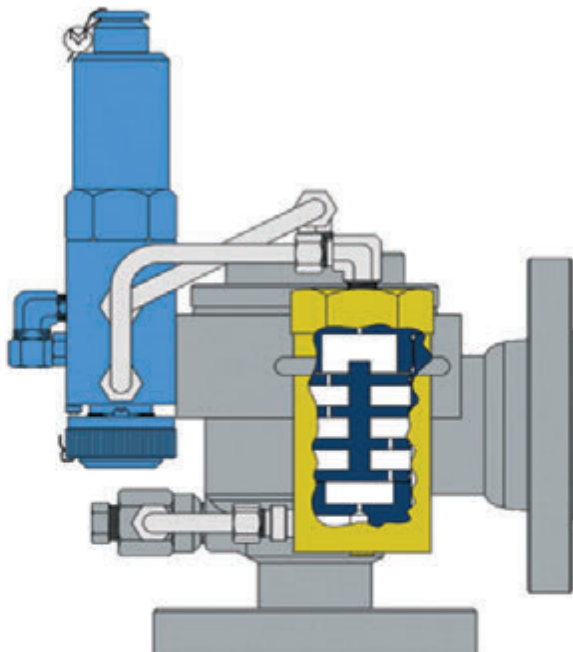

PRESSURE SNUBBER

A pressure snubber may be needed in applications where pressure surges are present. The pressure snubber works as a pressure dampener that reduces the effect of pressure spikes on the pilot valve. This type of accessory is commonly used in compressor applications.

9500 Series Pilot Operated Numbering System

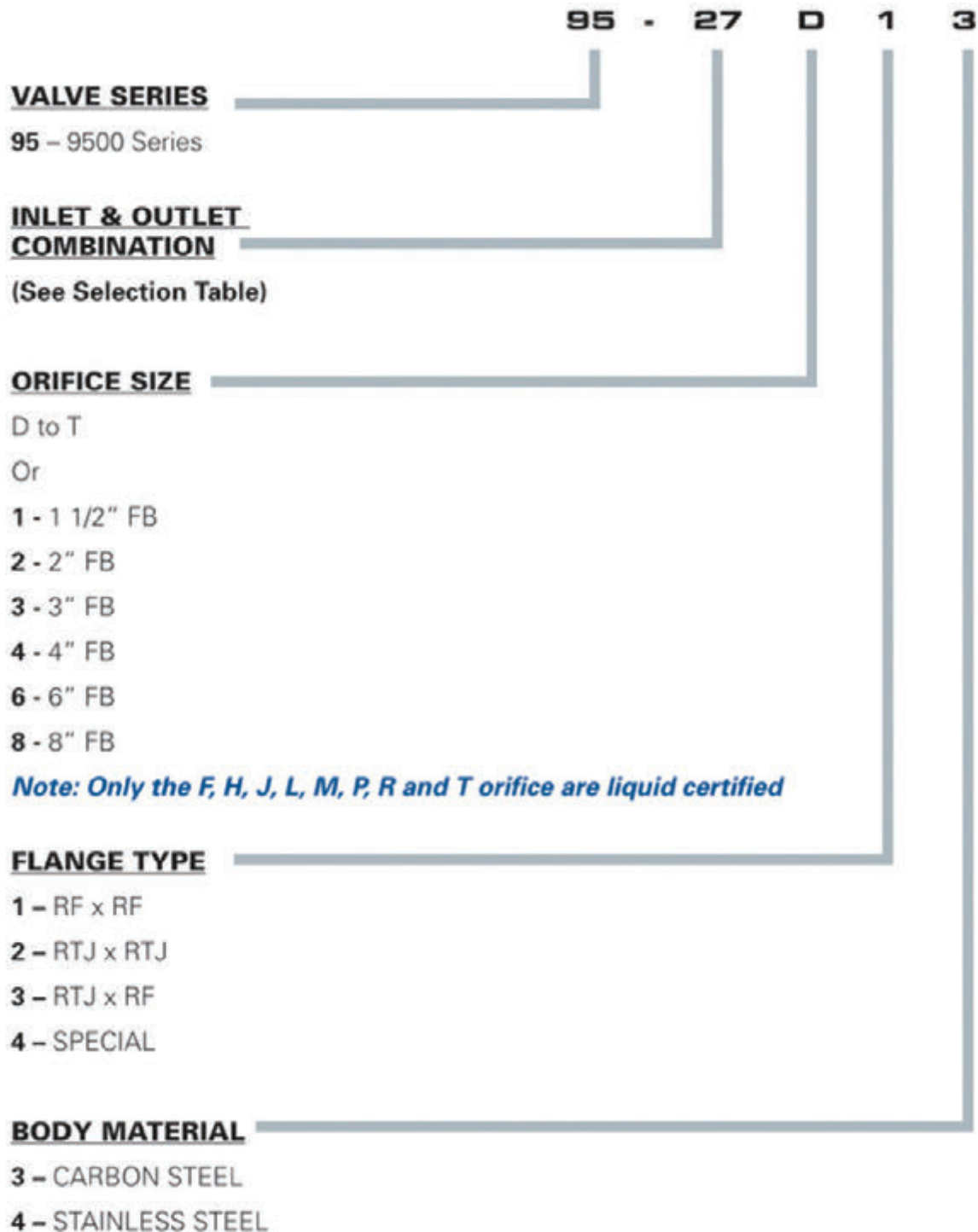

7



2 - DIGIT "SPECIAL" CODE
(IF APPLICABLE ASSIGNED BY MERCER)

PILOT TYPE

S - SNAP PILOT
M - MODULATING PILOT
L - LIQUID MODULATING PILOT

SOUR GAS SERVICE

N - IF APPLICABLE

SEAT MATERIAL

7 - TEFLON
8 - VITON
9 - PEEK

OPTIONS

0- NO OPTIONS
1- BACKFLOW PREVENTER
2- PRESSURE SNUBBER
3- PILOT FILTER*
4- 1 & 2
5- 1 & 3
6- 2 & 3
7- 1, 2, & 3

9500 Series Snap Pilot Numbering System

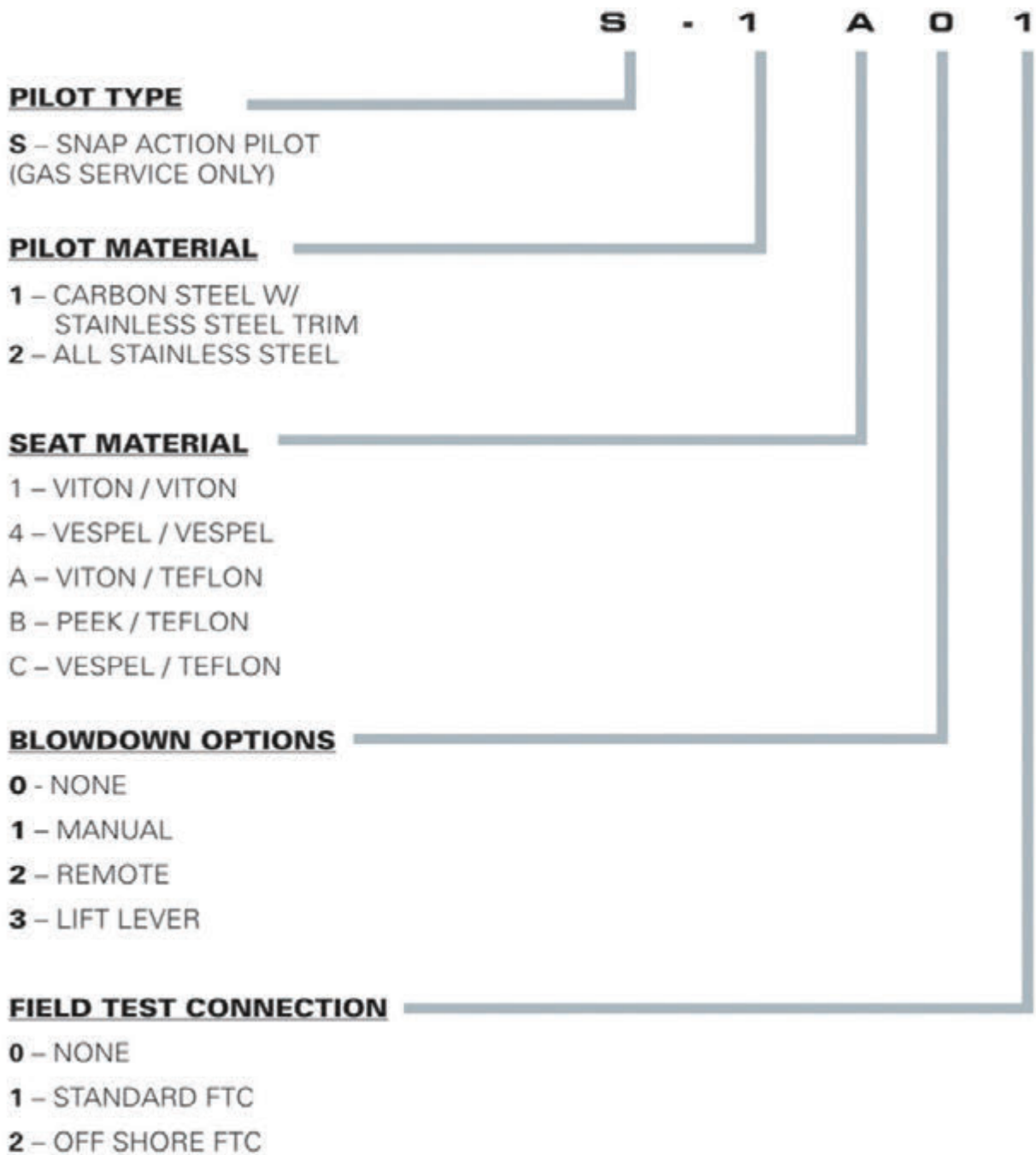

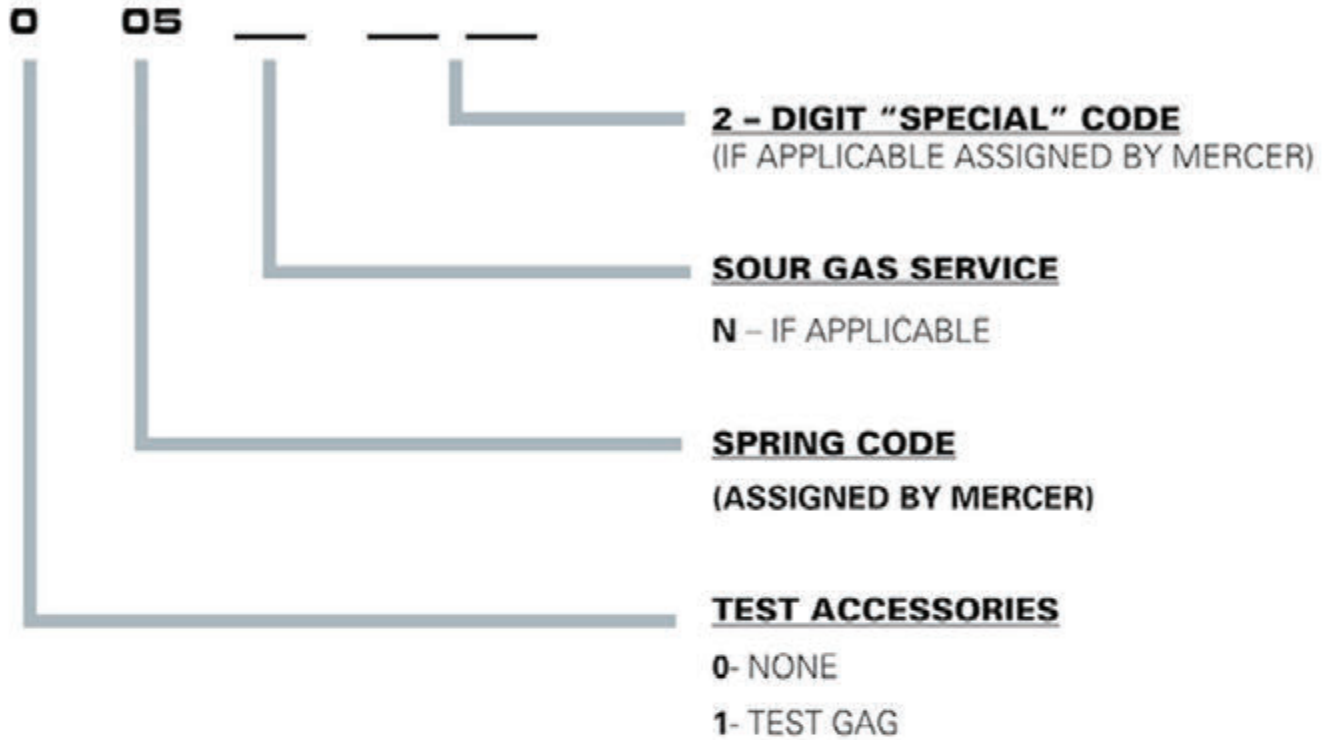

9500 Series Modulating Pilot Numbering System

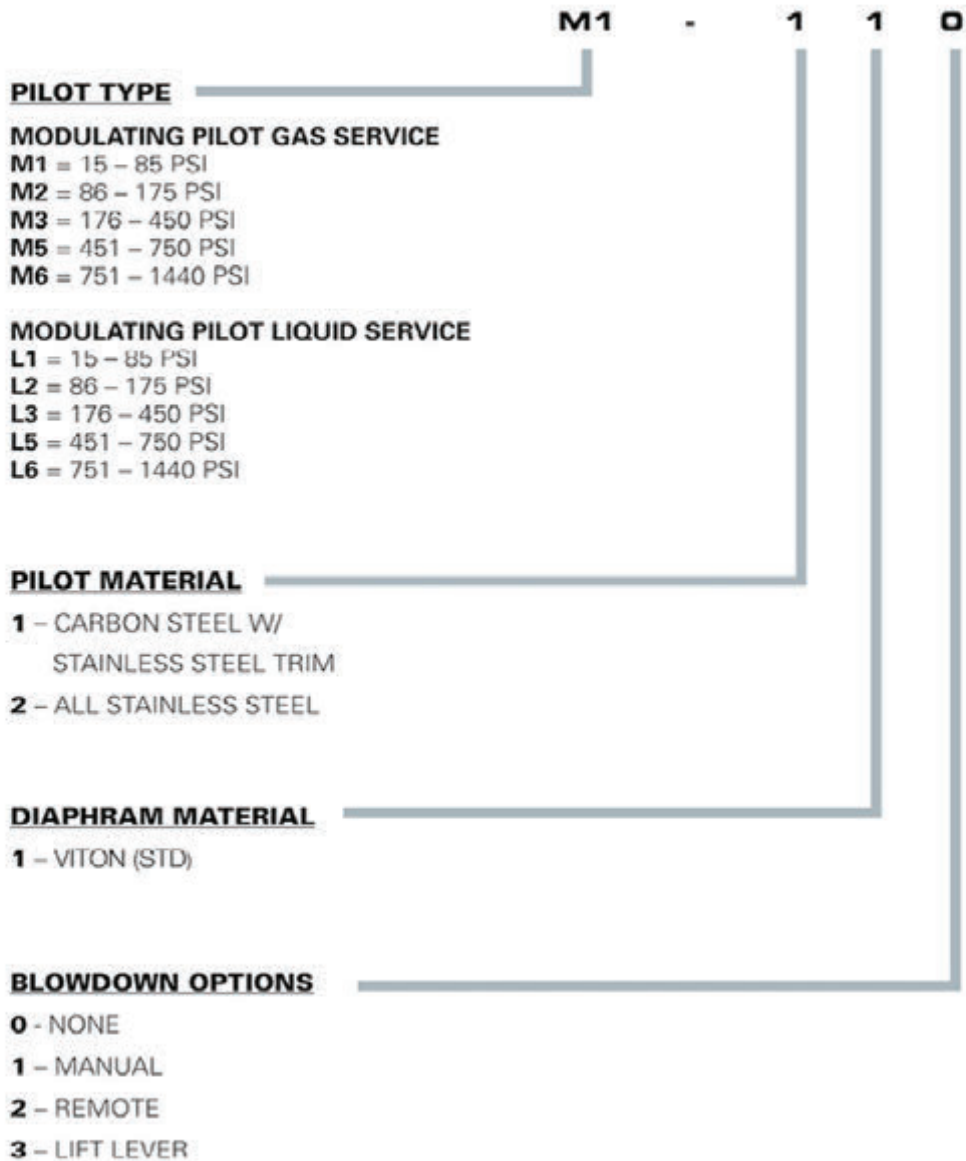

NOTE: Mercer Valve reserves the right to change product designs and specifications without notice.

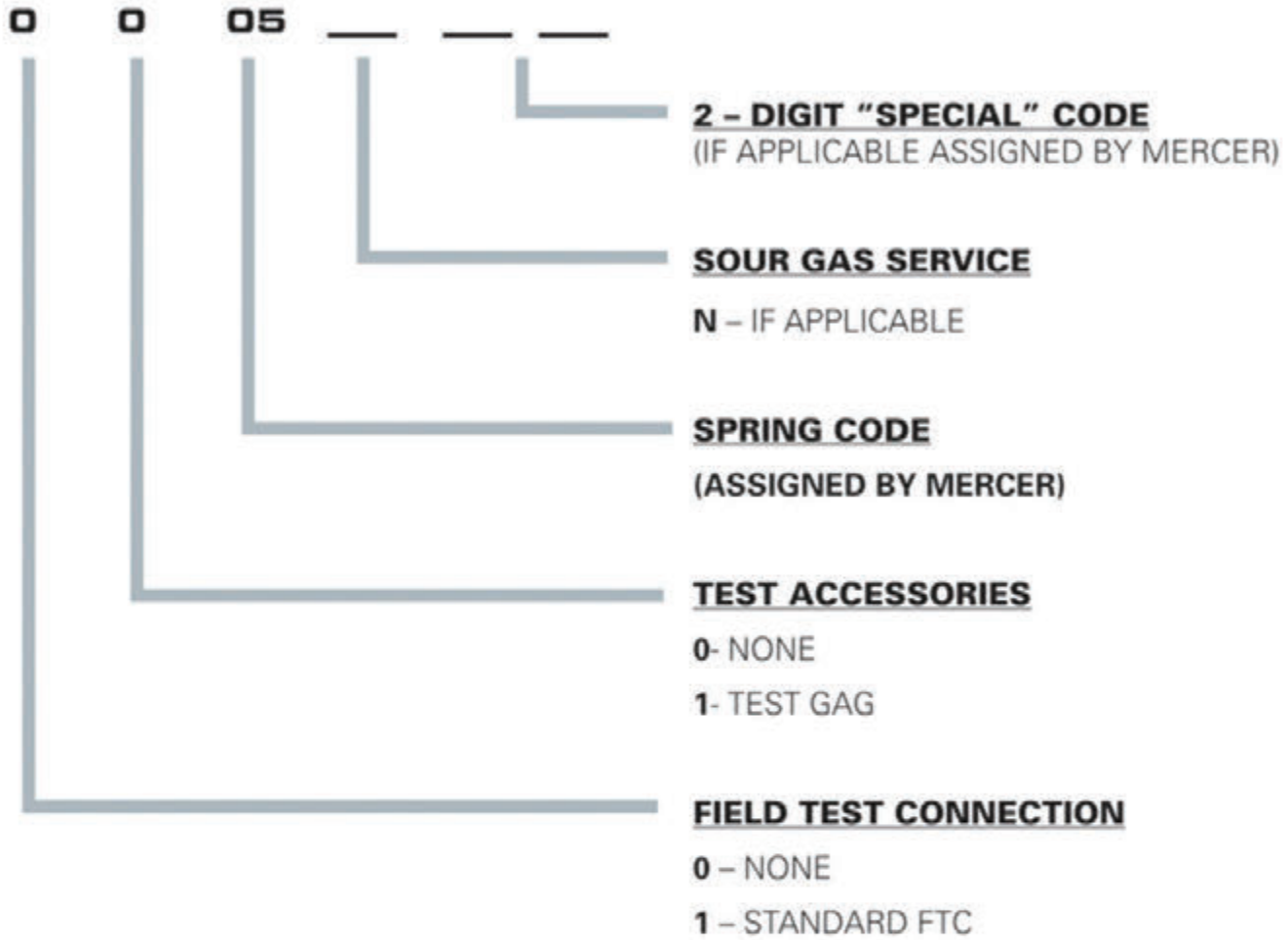



Western Gauge
Mercer Valve
Superlok
CheckPoint Pump
Warren Valve



A Division of the Unified Valve Group Ltd.

Visit our website at:

unifiedvalve.com

Email: customercare@unifiedvalve.com

Mercer Valve Canada

403.215.6961

3815 32 Street, NE
Calgary, AB T1Y 7C1